



METAL CLOSURES



PRY-OFF / TWIST-OFF CROWNS

Production process - flow

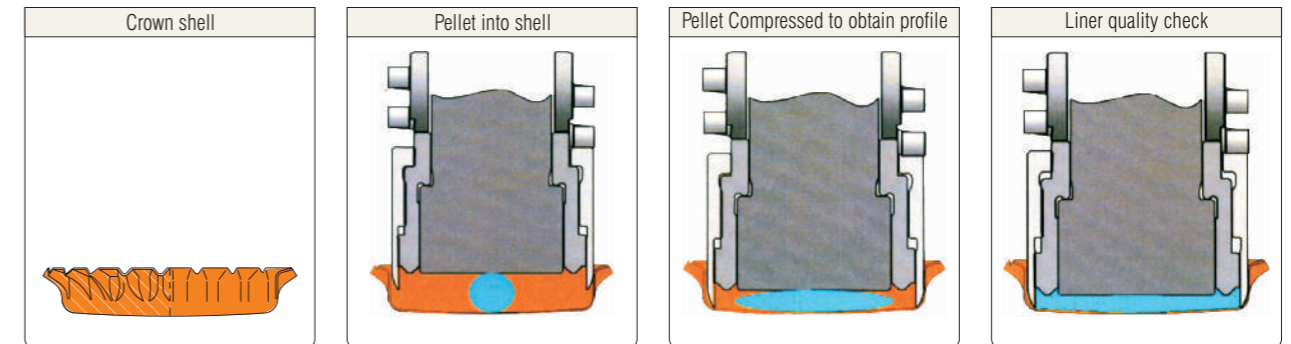

Liner profiles which can be made with PVC and PVC-free liner material

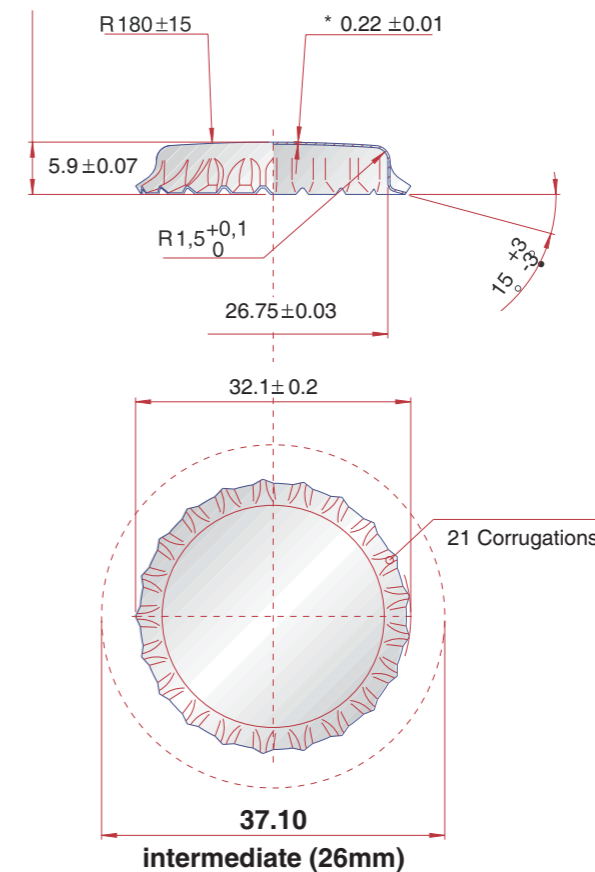

Metal Closures Private Limited
(an ISO 9001:2008 certified company)

Corporate office: 12th K.M., Kanakapura Road, Bangalore 560062, India.
Ph: +91 80 2608 7200 Fax +91 80 2632 0020
e-mail: admin@metalclosures.com www.metalclosures.com